

STELLAR AGGRESSOR™

9000-RS OTR



The Stellar Aggressor 9000-RS OTR series, features a rugged, heavy-duty 15' steel OTR service body with over 60 cubic feet of storage. The standard driver-side rail folds down, for ease and safety of loading and unloading of tires, as well as sign boards for identification.

The 9000-RS OTR is equipped with a model 9000 hydraulic knuckleboom crane. This crane is operated by a standard fully proportional radio remote control. The 90,000 foot-pound crane has a maximum lift capacity of 15,000 lbs. @ 6' and 6,000 lbs. @ 15'. The crane rotation is 290°, achieved through a turntable bearing with an external hour glass shaped worm gear. The hexagon shaped secondary and extension boom greatly increase boom strength over competitive square-shaped booms, ensuring solid performance.



All of the underbody tool compartments come standard with the exclusive Stellar slide top doors for unobstructive storage access. Stainless steel automotive style slam latches and hardware are standard on all tool compartments.



The left front storage compartment houses the 3/8" and 1/2" hose reels, along with the FLR (filter, lubricator and regulator) and a 12-volt trouble light reel.

The model SHD-66DD direct drive hydraulic air compressor is a 4-cylinder, 2-stage compressor with a 100 cubic inch displacement and an output capacity of 46 CFM @ 175 PSI.

Designed & Manufactured
in the USA

STELLAR
INDUSTRIES INC.

9000-RS OTR Series

STELLAR AGGRESSOR™ 9000-RS OTR



The Stellar 9000 OTR series is the only crane in its class to offer a variable speed handheld radio remote control as a standard feature. The radio remote control system allows operators to maintain a safe operating distance between themselves and the load. A push button on-off switch in the pistol grip handle ensures that the crane is activated only by the operator.



Model SHD-66DD direct drive hydraulic air compressor is a 4-cylinder, 2-stage compressor with 63.51 displacement CFM @ 175 PSI. The compressor is neatly mounted on the crane base to the right of the crane mast.



The performance of the 9000 OTR series can be enhanced by the addition of the TM4110 Tire Manipulator.

The TM4110 Tire Manipulator offers 140° of articulation and 240° of body rotation. This allows the operator to work in a variety of conditions while still working in a safe but speedy manner. The TM4110 has a clamping span of 50" to 104" and can handle tires or tire-rim combinations up to 4,600 lbs. The variation of clamping distances gives the 9000 OTR series with a TM4110 Tire Manipulator the ability to service fleets with small to medium sized OTR tires.

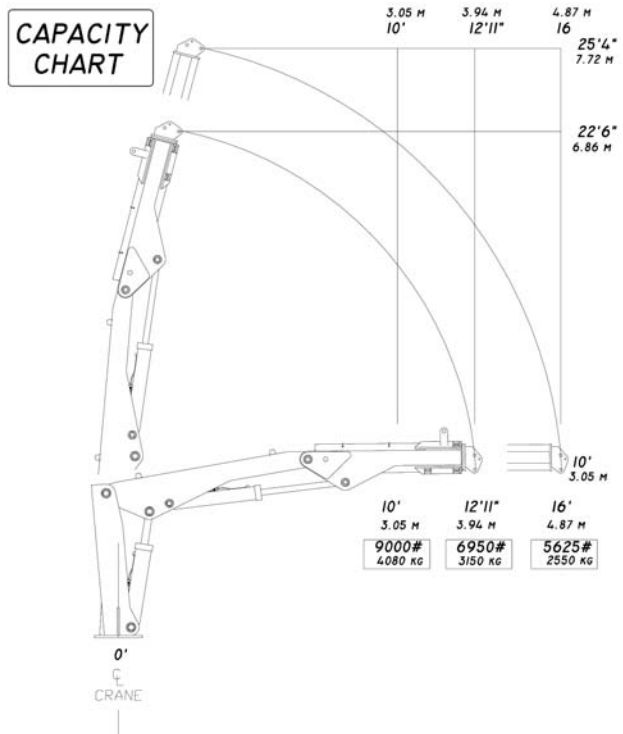

The chart above shows the lifting capacities and reach for the 9000 crane **without** the TM4110. TM4110 has a lifting capacity of 4600 lbs.



280 West Third Street
 Garner, Iowa 50438
 1-800-321-3741
 Fax: 641-923-2812
 E-mail: sales@tiretruck.com
 www.tiretruck.com

Designed & Manufactured in the U.S.A.

*Specifications may change without notification.
 Copyright © 2004 Stellar Industries, Inc.