



STELLAR SHUTTLE
MODEL 84-12-8 H
P/N(16259)
ASSEMBLY
AND
INSTALLATION
MANUAL

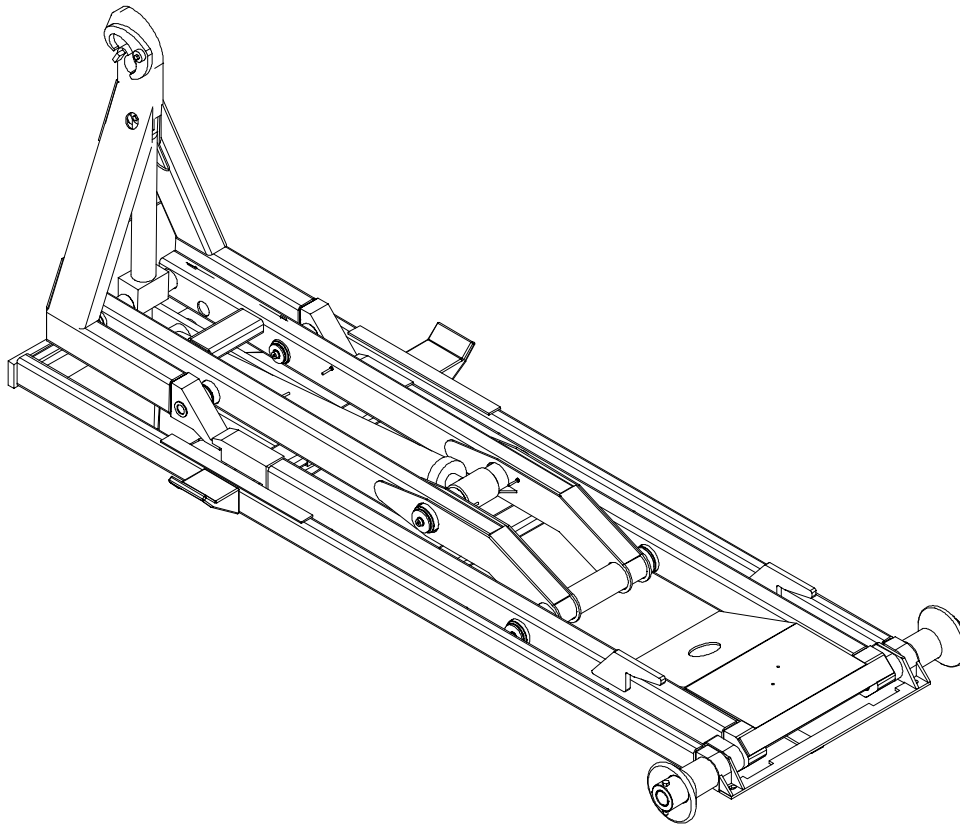

Table of Contents

Hydraulic Hook Lift Specifications	2
Base Assembly	3
Dump Assembly	4
Secondary Assembly	5
Tilt Assembly	6
Installation Instructions	7
Mounting Kit	8
Safety Valve Installation	9
Rotary Valve Assembly	10
Hydraulic Assembly	11
Tank Assembly	12
Hose Kit	13
Controller Assembly	14
Subframe	15
Warranty	16

Hydraulic Hook Lift Specifications

Lifting Capacity:	8,800 pounds gross weight evenly distributed in, or on, body.
Container Length:	10-foot through 13-foot from front A-frame to rear of skid rails. Longer bodies may be accommodated if full dump angle is not required (may require special body-mounted or extendable truck-mounted bumper to meet the Office of Motor Carrier Safety (OMCS) Rear End Protection regulation 393.86)
Maximum Dump Angle:	54°
Operating Pressure:	4200 PSI maximum
Weight of Loader:	Loader weight not to exceed 1,600 pounds
Height of Loader:	Loader height not to exceed 4" as measured from top of truck frame to top of loader rollers
Hook Height:	36.25-inches from bottom of skid rails to centerline of hook bar. Loader must be able to pick up 10-inches below grade when mounted on a truck with 34" frame height.
Hydraulic Pump:	Direct-coupled high-pressure gear pump.
Hydraulic Control Valve:	Stack-type valve mounted directed onto the oil reservoir.
Controls:	Dual manual levers with sealed cable actuators mounted in the truck cab to allow full feathering of all loader functions.
Tilting Hook Assembly:	Loader must have pivoting type front tilt section (jib) to provide a low degree loading/unloading angle. Hook to include automatic mechanical safety latch, which disengages only when the container/body is in proper position to be picked up or dropped off.
Tilt Cylinder:	Single 3-inch bore with 1.5-inch diameter rod cylinder. Cylinder must be double acting and include dual integral pilot-operated counterbalance valves to prevent cylinder collapse in case of hose failure.
Tilt Section Operation:	Loader must include a hydraulic lock-out device to prevent operation of the tilt section while loader is in the dumping mode.
Lift/Dump Cylinder:	Single 4-inch bore with 2-inch diameter rod cylinder. Cylinder must be double acting and include dual integral pilot-operated counterbalance valves to prevent cylinder collapse in case of hose failure.
Dump/Tilt Interlock:	Dumping must be accomplished through a rear pivot. Tilt and lift sections must lock into a rigid full length 25" wide frame with front saddles to provide support for the container while in the dump mode. These sections form this frame without the use of mechanical latches, which rely on gravity, springs, or container/body mounted latches.
Rear Body Hold-Downs:	Dual fixed-position hold-down devices mounted to the dump frame to secure the body to the loader through all ranges of the dump mode. This must be accomplished without the use of steel springs and/or hydraulic/air cylinders.
Rear Dump Hinge Pin:	2-inch diameter hardened, stainless steel minimum
Pins & Bushings	All pins to be hardened stainless steel. All bushings to be of the permanently lubricated variety. No grease zerks allowed.
Hoses & Hydraulic Fittings:	All hoses and fittings are to be SAE: metrics not allowed. O-ring face seal fittings to be utilized wherever possible.
Origin of Manufacture:	Loader to be designed and manufactured in the United States of America.

Base Assembly P/N(16267)

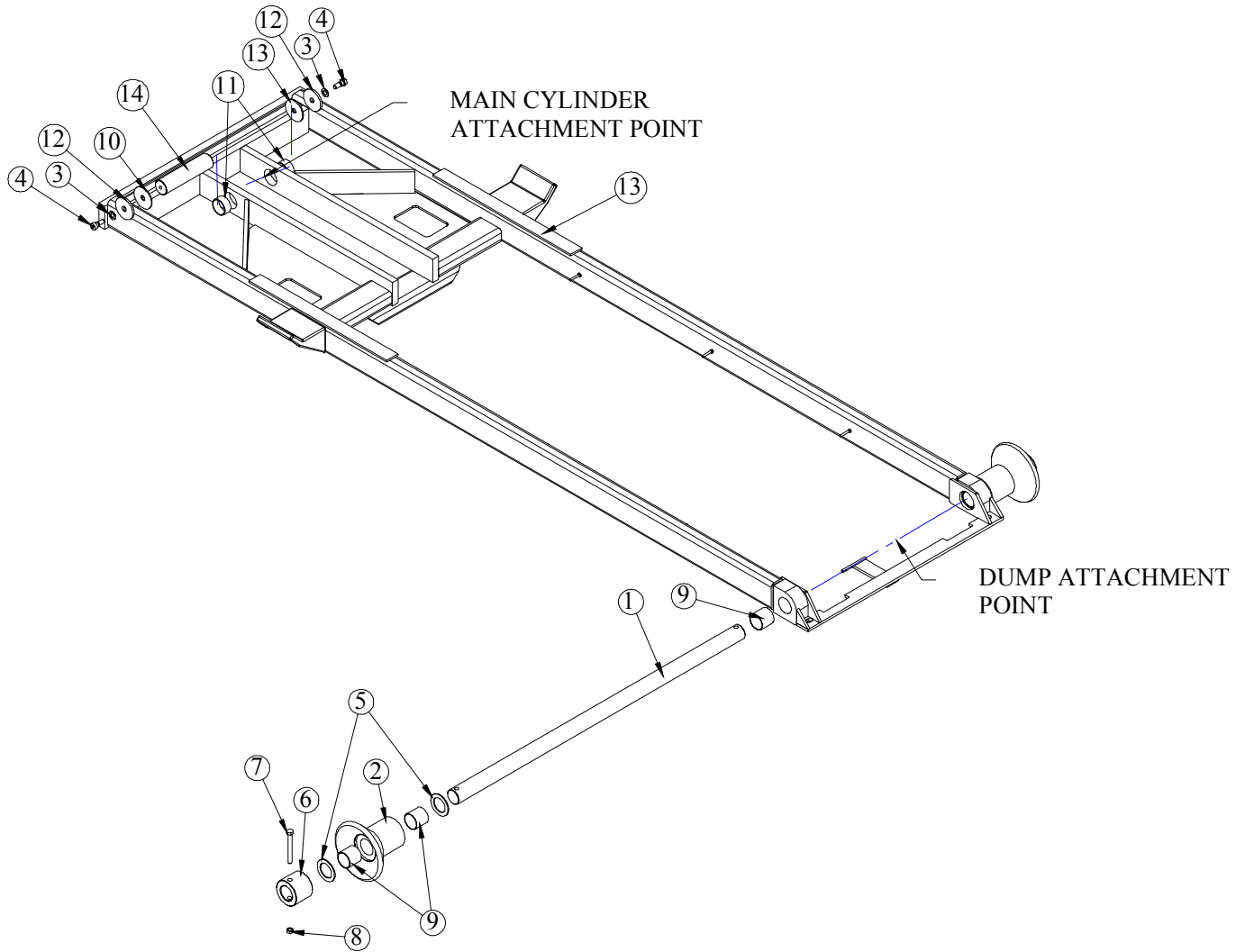

ITEM	PART	DESCRIPTION	QTY.
1	0060	PIN DUMP	1
2	0013	ROLLER	2
3	12711	THRUST WASHER 0.63 DIA	2
4	12673	CAP SCREW 0.50-13 SHOULDER	2
5	1546	THRUST WASHER 2.01DIA UHMW .12THK	4
6	0015	COLLAR 2.01X3.50X2.88	2
7	0507	CAP SCR 0.50-13X4.50 HHGR5	2
8	C6106	NUT 0.50-13 HHGR5 NYLOC	2
9	0066	BUSHING QSI-3235-32	6
10	12719	THRUST WASHER 0.64x3.00x0.125	2
11	8819	BUSHING QSI-3235-16	2
12	8454	PIN CAP 0.69x3.00x0.25 SS	2
13	16260	BASE 84-12-8H	1
14	16266	PIN 2.00X8.19 D&T	1

Dump Assembly P/N(16268)

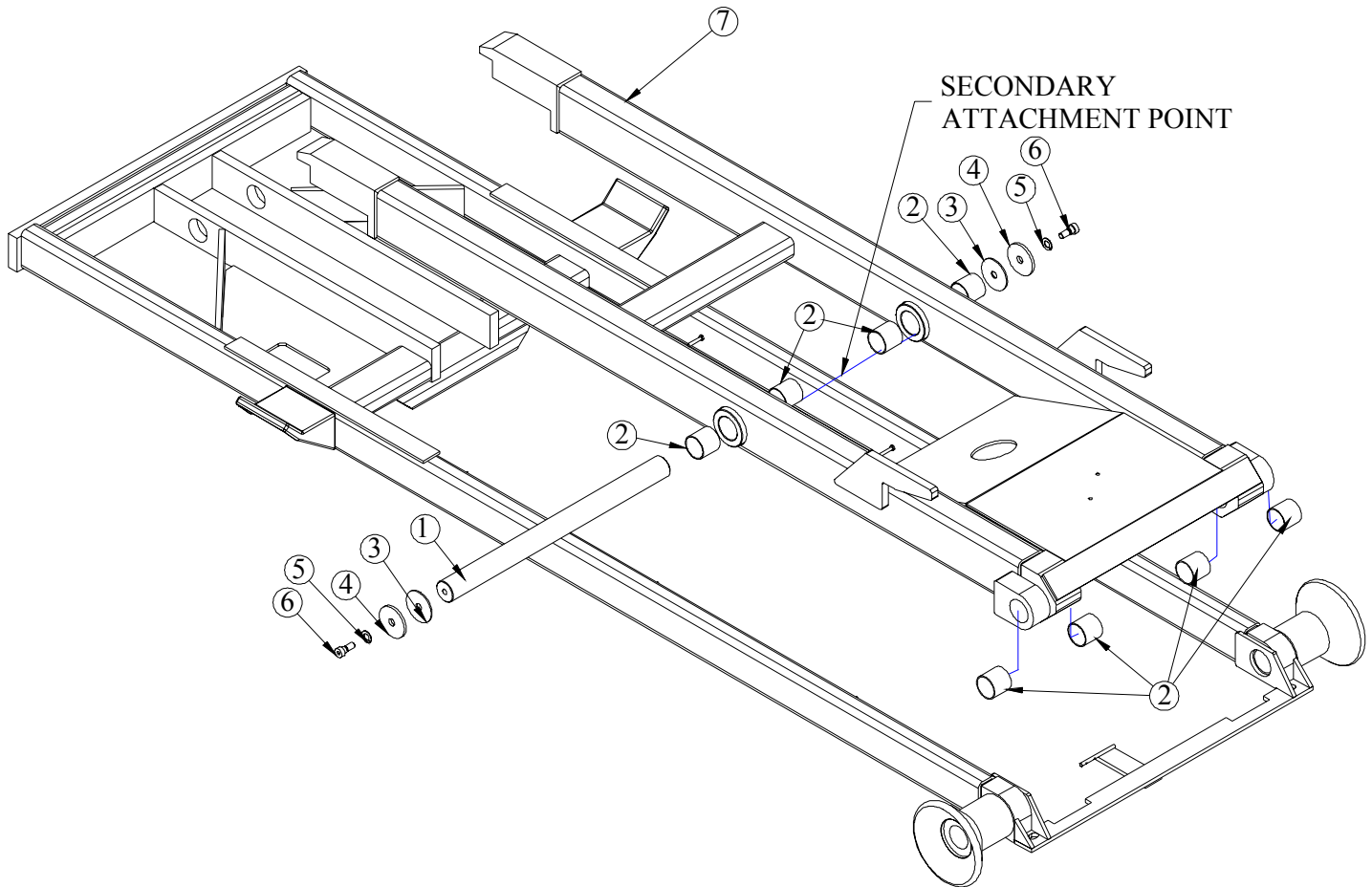

ITEM	PART	DESCRIPTION	QTY.
1	4438	PIN 2.00X26.25 D&T	1
2	0066	BUSHING QSI-3235-32	8
3	12719	THRUST WASHER 0.64x3.00x0.125	2
4	8454	PIN CAP 0.69x3.00x0.25 SS	2
5	12711	THRUST WASHER 0.63 DIA	2
6	12673	CAP SCREW 0.50-13 SHOULDER	2
7	16261	DUMP 84-12-8H	1

Secondary Assembly P/N(16269)

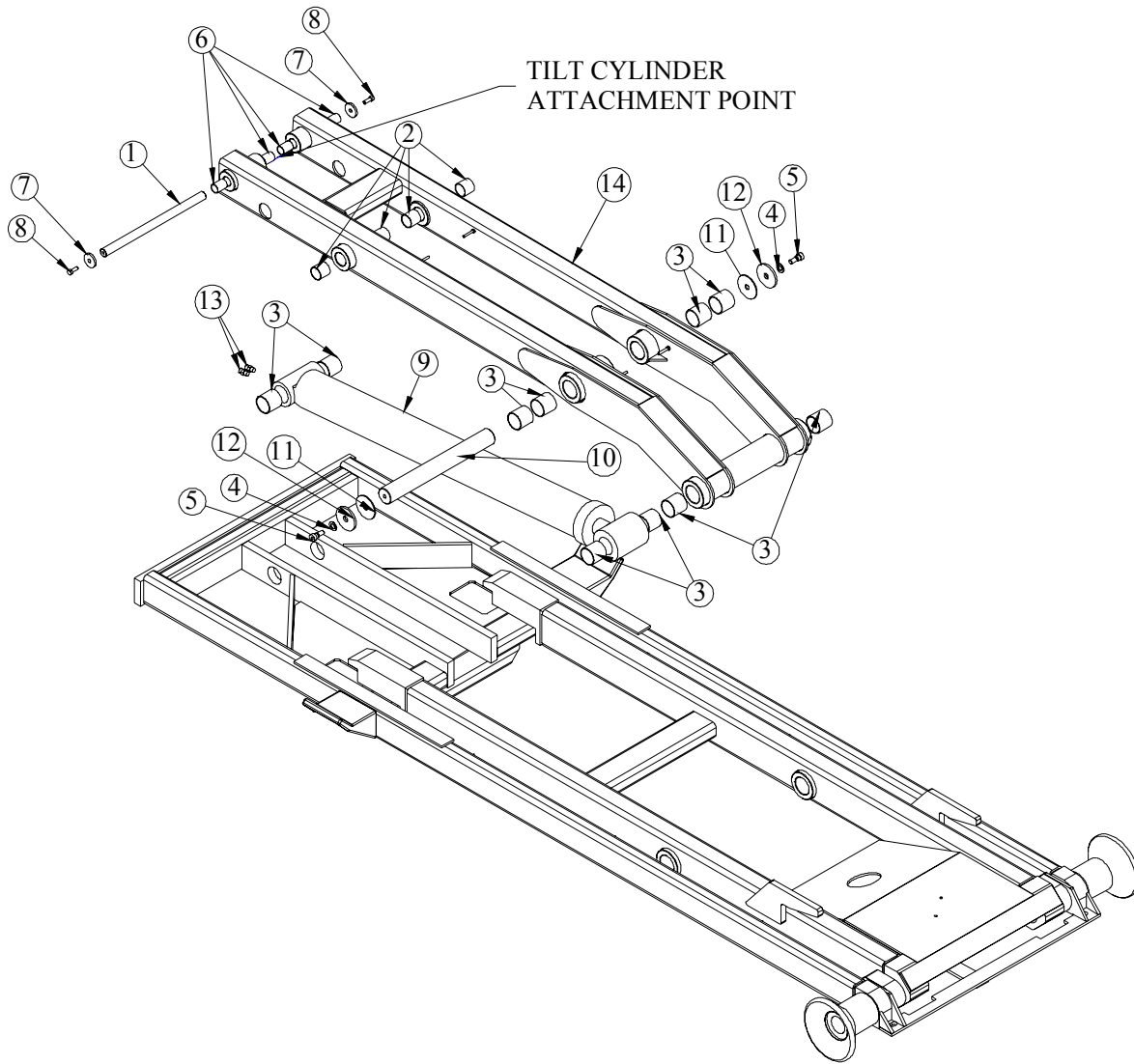

ITEM	PART	DESCRIPTION	QTY.
1	14620	PIN 1.00X16.25 D&T	1
2	0067	BUSHING QSI-2426-24	4
3	0066	BUSHING QSI-3235-32	10
4	12711	THRUST WASHER 0.63 DIA	2
5	12673	CAP SCREW 0.50-13 SHOULDER	2
6	0068	BUSHING QSI-1618-24	4
7	9320	PIN CAP 0.44X1.75X0.25 SS	2
8	9714	CAP SCR 0.38-16X1.00 SS	2
9	0315	CYLINDER 5.00X40.38	1
10	15238	PIN 2.00X17.00 D&T	1
11	12719	THRUST WASHER 0.64x3.00x0.125	2
12	8454	PIN CAP 0.69x3.00x0.25 SS	2
13	0279	FTG ADAPT 6-F5OLO-S	2
14	16262	SECONDARY 84-12-8H	1

Tilt Assembly P/N(16222)

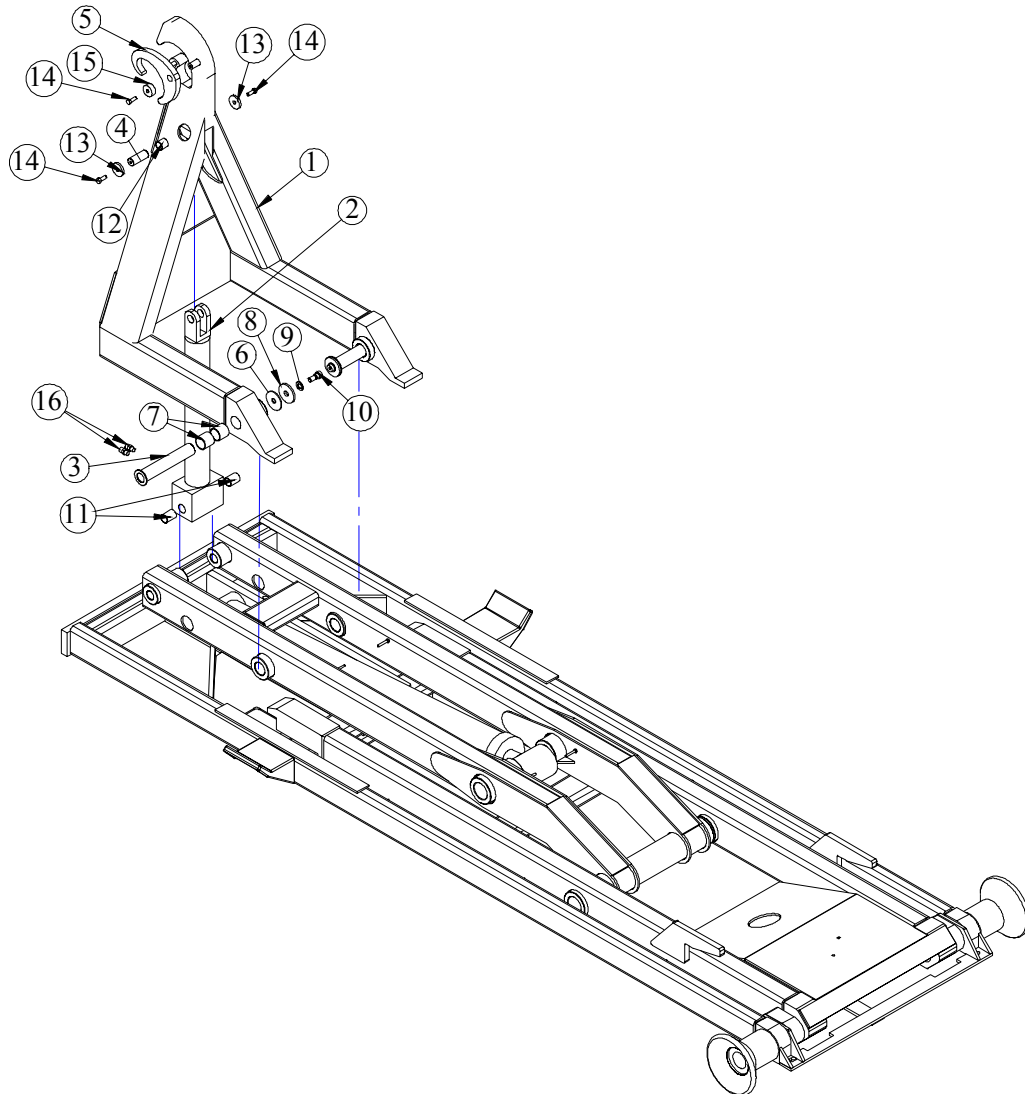

ITEM	PART	DESCRIPTION	QTY.
1	16042	TILT 60-10-8H	1
2	0058	CYLINDER 3.00X14.00	1
3	15898	PIN WELDM'T 1.50X8.38 D&T	2
4	14671	PIN 1.00X2.50 D&T	1
5	0295	LATCH 12,000#	1
6	15934	THRUST WASHER 0.64x2.50x0.125	2
7	0067	BUSHING QSI-2426-24	4
8	15933	PIN CAP 0.69x2.50x0.25 SS	2
9	12711	THRUST WASHER 0.63 DIA	2
10	12673	CAP SCREW 0.50-13 SHOULDER	2
11	0068	BUSHING QSI-1618-24	2
12	0069	BUSHING QSI-1618-16	1
13	9320	PIN CAP 0.44X1.75X0.25 SS	2
14	9714	CAP SCR 0.38-16X1.00 SS	3
15	14672	PIN CAP 0.44X1.50X0.63	1
16	0279	FTG ADAPT 6-F5OLO-S	2

INSTALLATION INSTRUCTIONS

READ ALL INSTRUCTIONS BEFORE PROCEEDING

MOUNT PTO AND PUMP

MOUNT RESERVOIR VALVE COMBO TO TRUCK FRAME

CONNECT SUCTION AND PRESSURE TO TANK, VALVE BANK, AND PUMP

FILL OIL RESERVOIR TO SIGHT GAUGE (MOBIL DTE 13M IS RECOMMENDED)

INSTALL CONTROLLERS AND CABLES IN CAB

SET SHUTTLE ON THE TRUCK SO THAT ITS FRONT PLATE IS AT LEAST 2" BEHIND THE CAB

SQUARE THE SHUTTLE ON THE TRUCK FRAME

DRILL 2-11/16" DIAMETER HOLES THROUGH THE TRUCK FRAME AT THE BACK USING THE LOADER'S HOLES AS A GUIDE

USING 5/8" BOLTS, WASHERS AND NUTS, BOLT THE REAR OF THE LOADER TO THE TRUCK FRAME

SHORTEN THE TRUCK FRAME TO ABOUT 2" FROM THE REAR TO THE LOADER

USING 5/8" BOLTS, WASHERS, AND NUTS FASTEN 2 TIE DOWN CHANNELS TOGETHER WITH THE NARROW FACES TOWARDS EACH OTHER, DO THIS WITH ALL 8 CHANNELS(NOTE:USE INCLUDED SPACERS IF NECESSARY FOR CLEARANCE)

PLACE THE TIE DOWN CHANNELS IN THE APPROXIMATE POSITIONS SHOWN ON PAGE 8, WITH THE TOP OF THE LOWER CHANNEL FLUSH TO THE TOP OF THE TRUCK FRAME (NOTE: FRONT TIE DOWNS **MUST** BE WITHIN 6 INCHES OF THE FRONT OF THE LOADER)

USING THE MOUNTING CHANNELS AS A GUIDE, DRILL (6) 11/16" HOLES THROUGH THE TRUCK FRAME.

USING 5/8" BOLTS, WASHERS, AND NUTS SECURE ALL TIE DOWNS TO THE TRUCK FRAME

WELD THE UPPER TIE DOWNS TO LOADER BASE

CONNECT HOSES TO VALVE BANK AS INDICATED IN HYDRAULIC ASSEMBLY

SET THE RELIEF VALVE TO 4200 PSI

OPERATE THE LOADER TO ELIMINATE AIR FROM THE SYSTEM

CHECK THE OIL LEVEL AND ADD OIL IF REQUIRED

Mounting Kit P/N(16230)

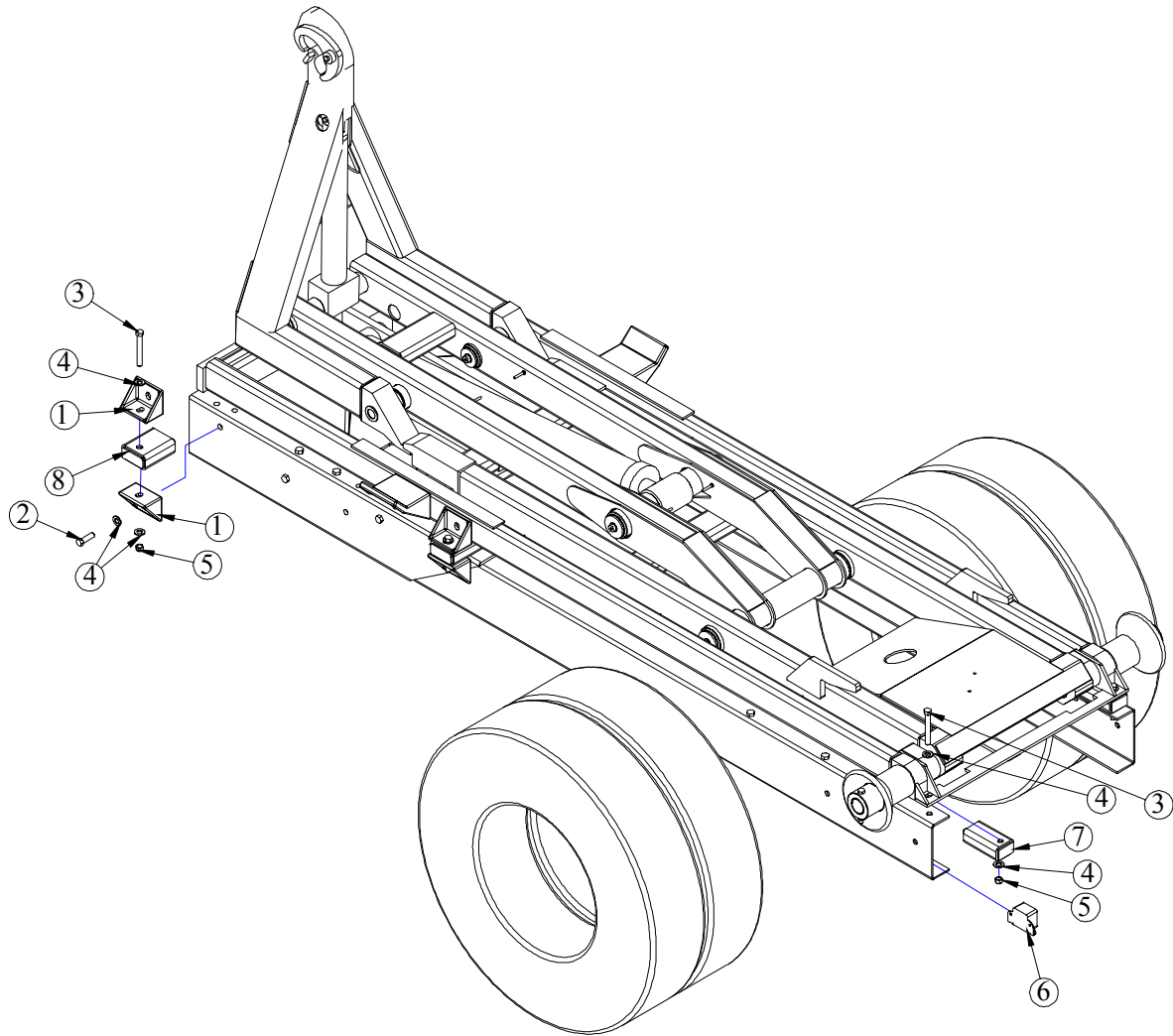

ITEM	PART	DESCRIPTION	QTY.
1	D0143	TIE DOWN CHANNEL	8
2	0399	CAP SCR 0.63-11X2.00 HHGR5	4
3	0512	CAP SCR 0.63-11X4.50 HHGR5	6
4	0358	WASHER 0.63 FLAT SAE	20
5	2826	NUT 0.63-11 HH NYLOC	10
6	D0045	OVERLOAD ALARM	1
7	0640	TIE DOWN SPACER	2
8	16229	TIE DOWN SPACER 2X4	4

Safety Valve Installation

Incorporated into the standard Stellar Hooklift is a safety valve designed to protect the dump section tabs from being damaged by the tilt section.

It is important to locate this valve properly for safe operation of the Stellar Hooklift.

This cartridge is located in the main valve stack and **MUST** be placed off of the tilt cylinder retract port. The following illustrations show a standard (driver side) installation and an optional (passenger side) installation. Passenger side installations are common when mounting to cab-over chassis. All valve stacks are shipped for standard (driver side) installations. The safety valve must be moved to the tilt cylinder retract port for all non-standard installations. This valve will be switched with a load check plug when being moved to an alternate position. A poppet and spring are located behind the safety valve and load check plugs. Care should be taken not to lose these parts when modifying.

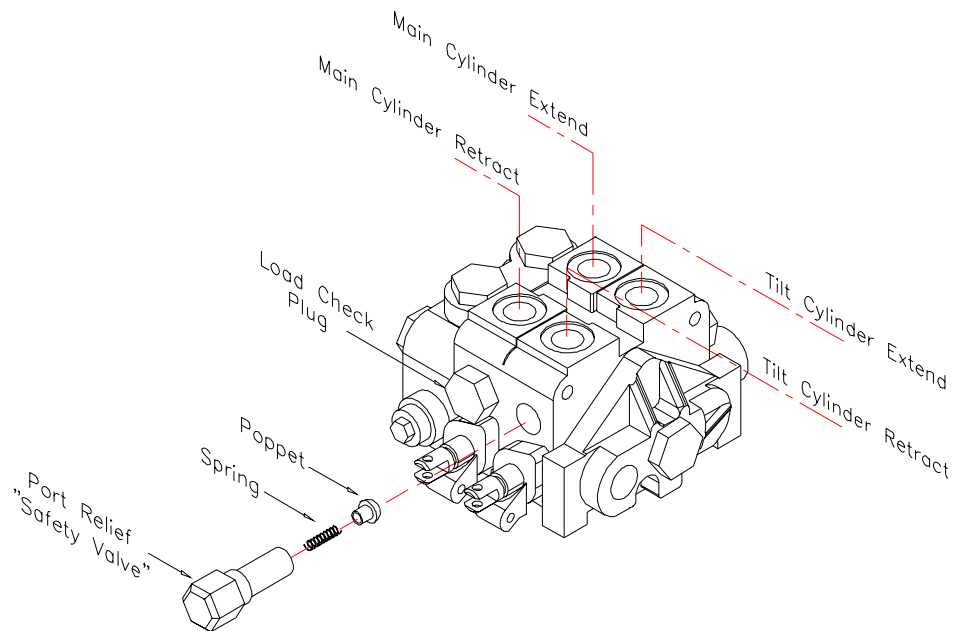

Valve stack for standard installation

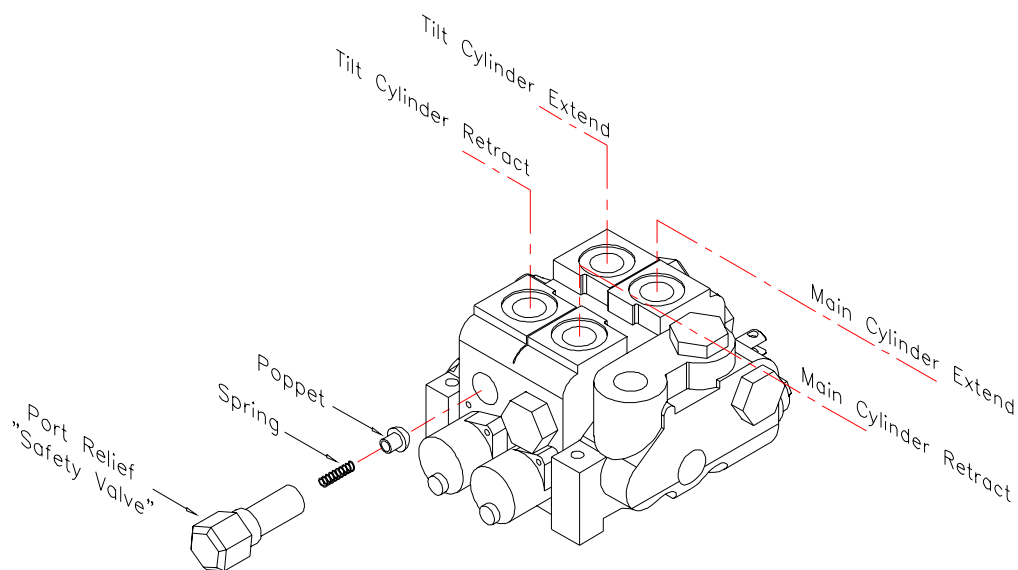

Valve stack for non-standard installation

Rotary Valve Installation

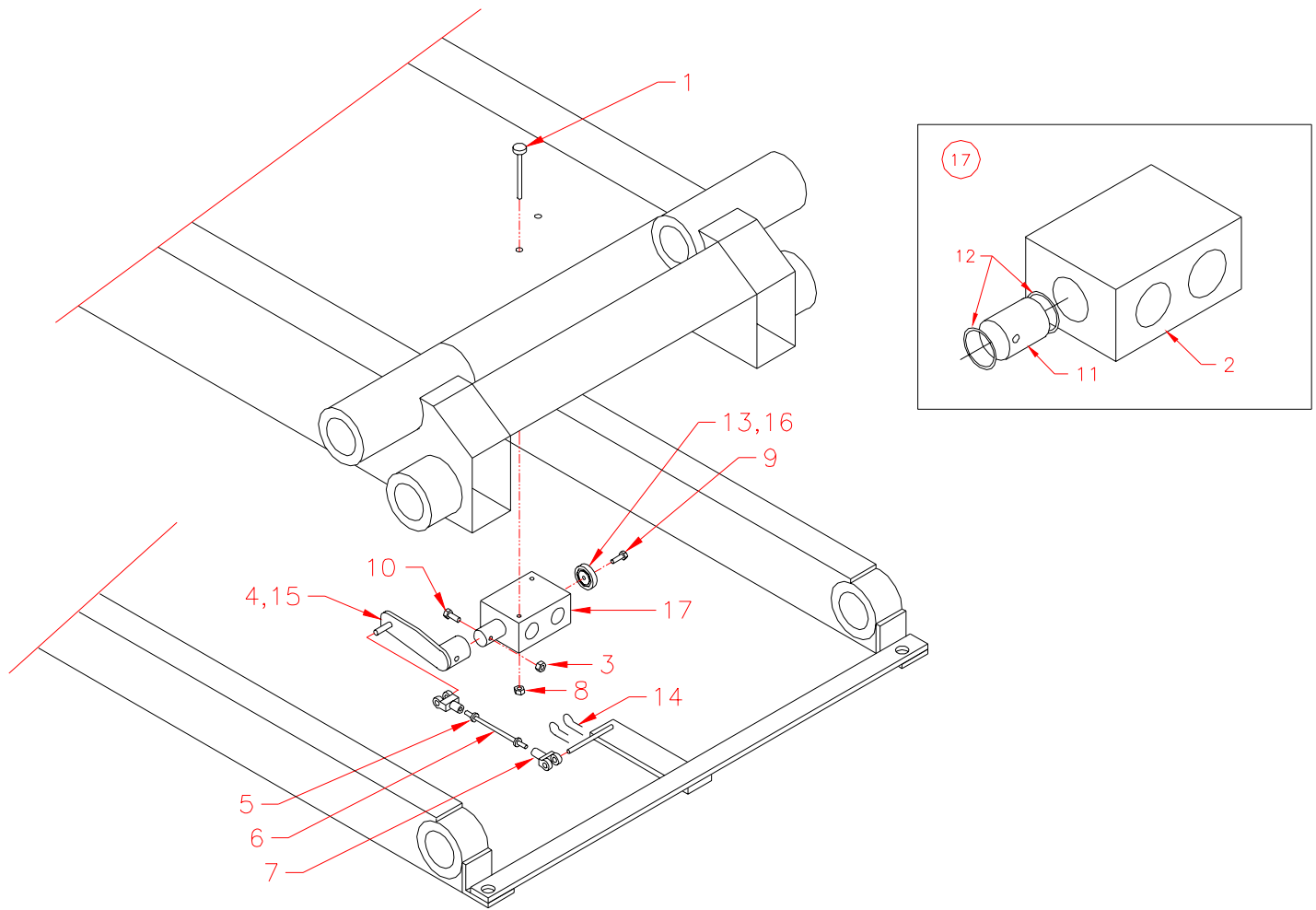

ITEM	P/N	DESCRIPTION	QTY	ITEM	P/N	DESCRIPTION	QTY
1	0482	Cap Screw, 0.25-20x3.00	2	10	0353	Cap Screw, 0.38-16x2.00	1
*2	0933	Body, Rotary Valve	1	*11	D0270	Spool, Rotary Valve	1
3	0347	Nut, 0.38-16 Nyloc	1	*12	0979	Seal, U-Cup	2
4	1521	Rod, Rotary Valve	1	13	3748	Washer, Rotary Valve	1
5	2478	Nut, 0.31-24	2	14	C6113	Cotter, 0.094x1.00	2
6	2476	Rod, 0.31-24 Threaded GR7	12"	15	0977	O'Ring, 1.00x1.25x0.12	1
7	2479	Clevis, 0.31 Pin	2	16	D1638	O'Ring, 1.12x1.38x0.12	1
8	0333	Nut, 0.25-20 Nyloc	2	17	0877	Rotary Valve Assembly	1
9	0480	Cap Screw, 0.25-20x1.00	1				

* Items are part of #17(0877- Rotary Valve Assembly)

Hydraulic Assembly P/N 17542

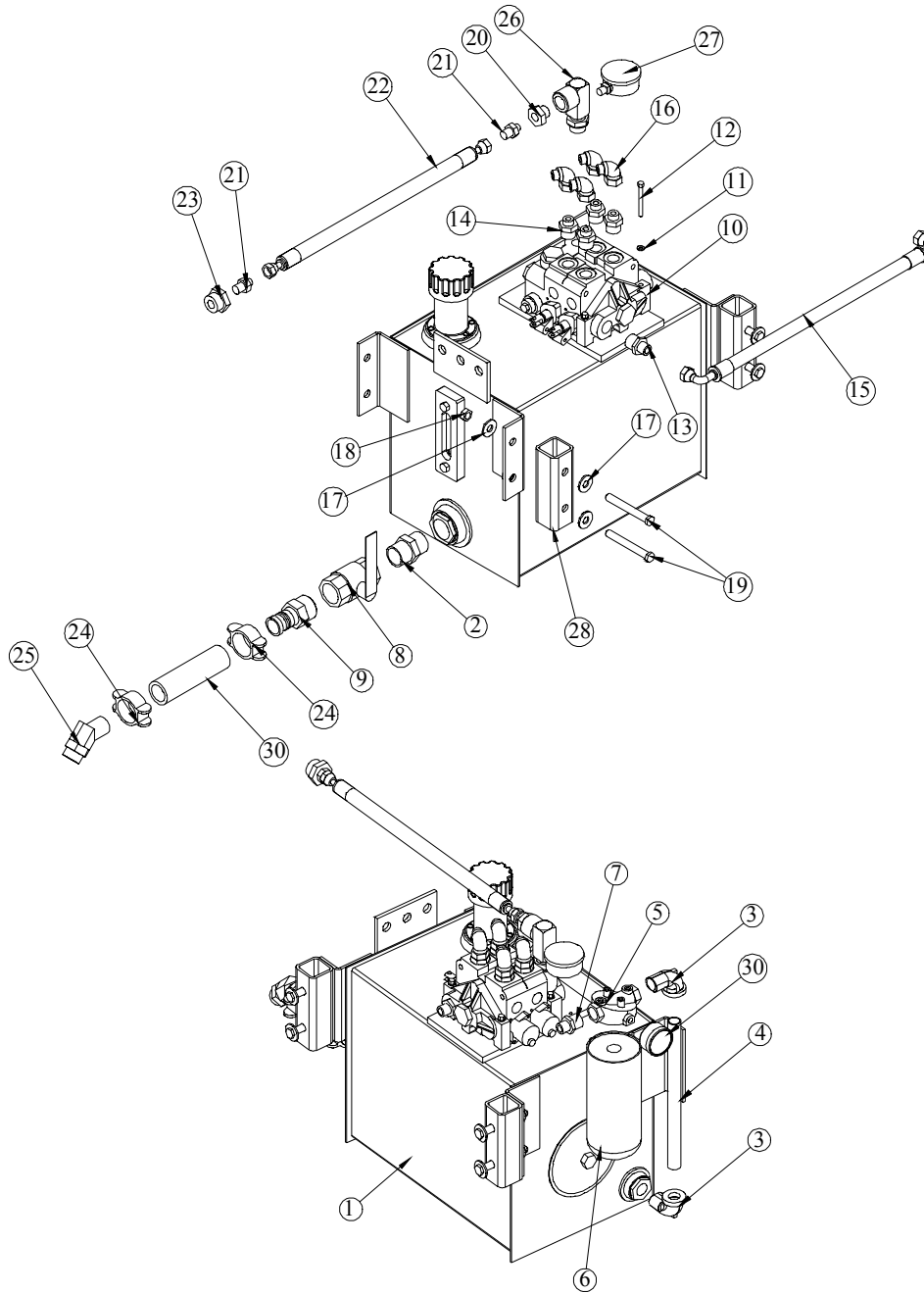

ITEM NO.	PART NO.	DESCRIPTION	QTY.	ITEM NO.	PART NO.	DESCRIPTION	QTY.
1	15623	RSRVR ASM 10GAL	1	16	C2248	FTG ADAPT 6-C6LO-S	4
2	1115	FTG NIPPLE HEX MALE 0101-20-20	1	17	0352	WASHER 0.50 USS FLAT ZINC	8
3	c2242	ST EL 0.75 90 DEG BLK	2	18	C6106	NUT 0.50-13 HHGR5 NYLOC	4
4	3320	NIPPLE 0.75X12.00 PIPE	1	19	0506	CAP SCR 0.50-13X4.00 HHGR5	4
5	c6226	FILTER HEAD	1	20	C2053	FTG ADAPT 6-8 FSOLO-S	1
6	C6229	FILTER LARGE AE-10L	1	21	C1854	FTG ADAPT 6-8 FSOLO-S	2
7	C6014	FTG ADAPT 8-12 FOLO-S	1	22	14927	HOSE 0.38(381-JC-JC-6-6-120)	1
8	C5511	VALVE BALL 1.25	1	23	D0549	FTG ADAPT 16-8 F5OG5-S	1
9	C2282	FTG 1.25 NPT TO 1.25 BARB	1	24	C1123	HOSE CLAMP 88 DB-20	2
10	2380	VB 2 SECT GRESEN V20	1	25	C4747	NIPPLE O'RING 45 4603-20-16	1
11	0521	WASHER 0.25 LOCK	3	26	14631	FTG MSTR/FSTR 90 12-12 HOOKLIFT	1
12	0339	CAP SCR 0.25-20X2.50 HHGR5	3	27	10094	GAUGE OIL LF 2.5" 0-500 BM	1
13	C1180	FTG ADAPT 8-12 FSOLO-S	1	28	9892	SPACER TANK MOUNTING 10 GAL	2
14	C1855	FTG ADAPT 6-10 FSOLO-S	4	29	16145	GAUGE PRES FILTER SERVICE CI20	1
15	14826	HOSE 0.50(381-J9-J9-8-8-18-0)	1	30	17767	HOSE SUCT 1.25 10FT	1

Tank Assembly P/N 15623

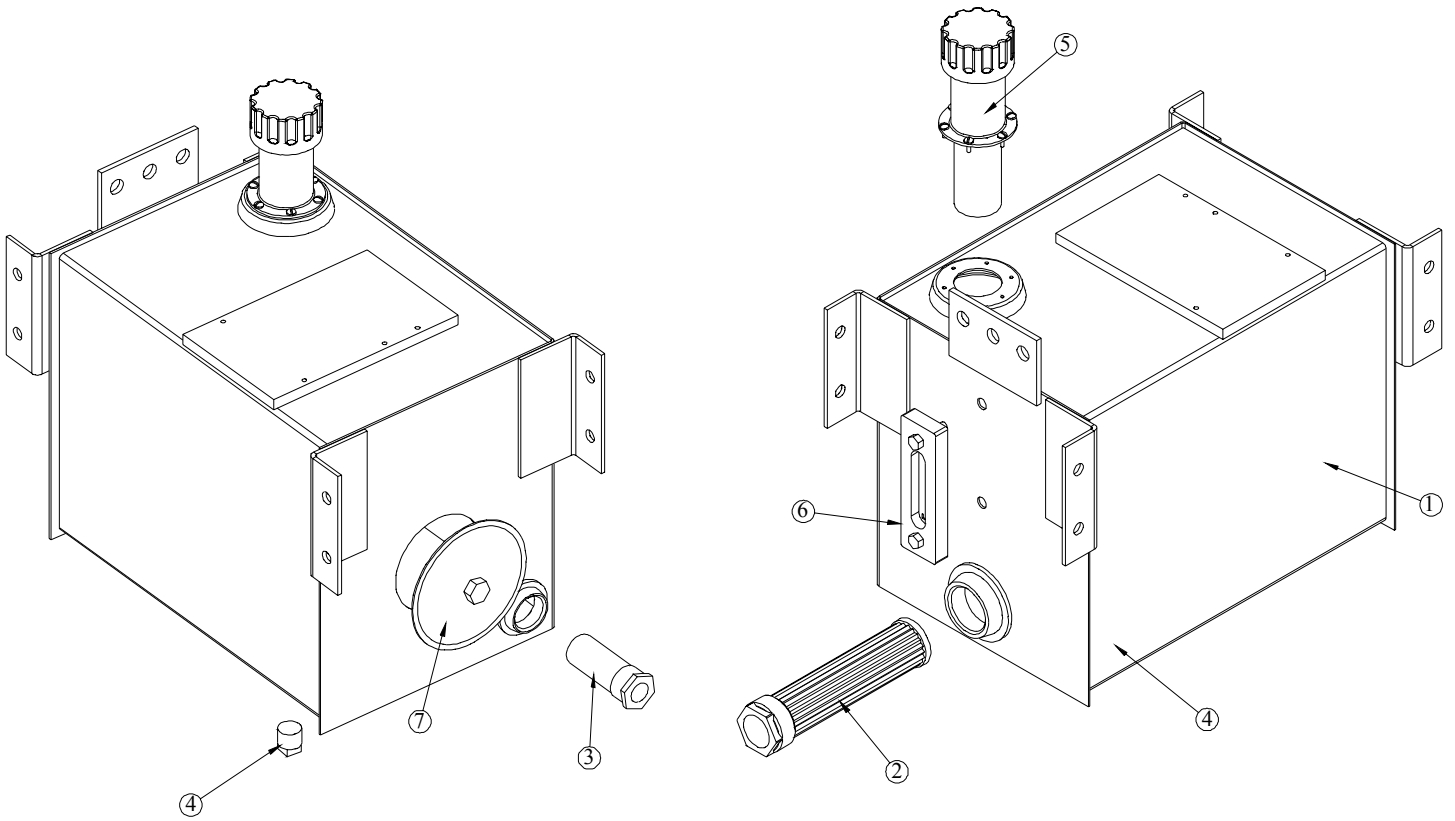

ITEM NO.	PART NO.	DESCRIPTION	QTY.
1	15622	RSRVR 10GAL	1
2	C5552	FILTER STRAINER TF-1220-0	1
3	C6326	DIFFUSER 5-17GAL	1
4	C2126	MAGNETIC PLUG DRAIN 3/4"	1
5	15462	CAP FILL ASM W/3" NECK	1
6	15463	THERMO SIGHT GAUGE	1
7	15464	TANK COVER	1

HOSE KIT P/N 15935

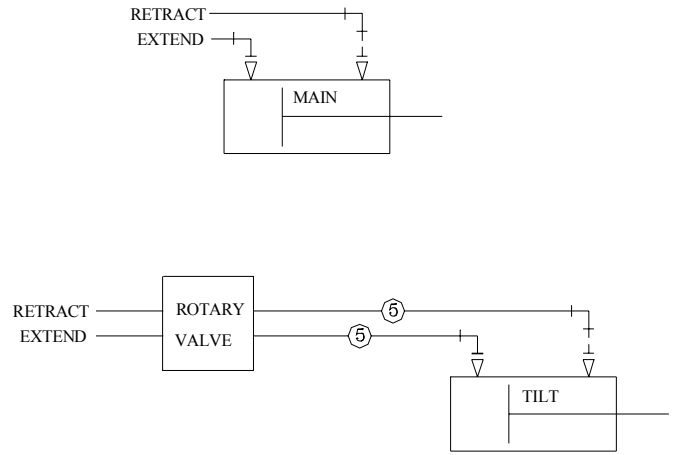
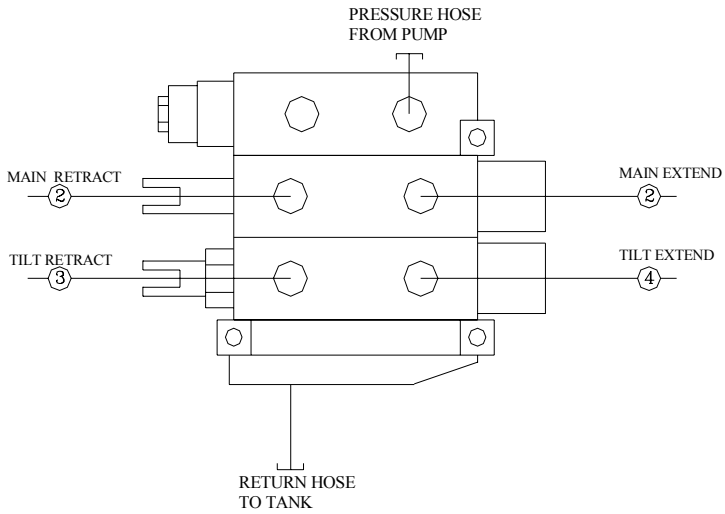

NOTE: IF RESERVOIR IS MOUNTED ON CS, HOSES 3 AND 4 ARE REVERSED

ITEM	PART	DESCRIPTION	QTY.
1	15935	HOSE KIT 84-12-12(ITEMS 2-5)	1
2	14827	HOSE 0.38X60.00	2ref
3	15937	HOSE 0.25X184.00	1ref
4	15189	HOSE 0.25X160.00	1ref
5	15936	HOSE 0.25X115.00	2ref

Controller Assembly

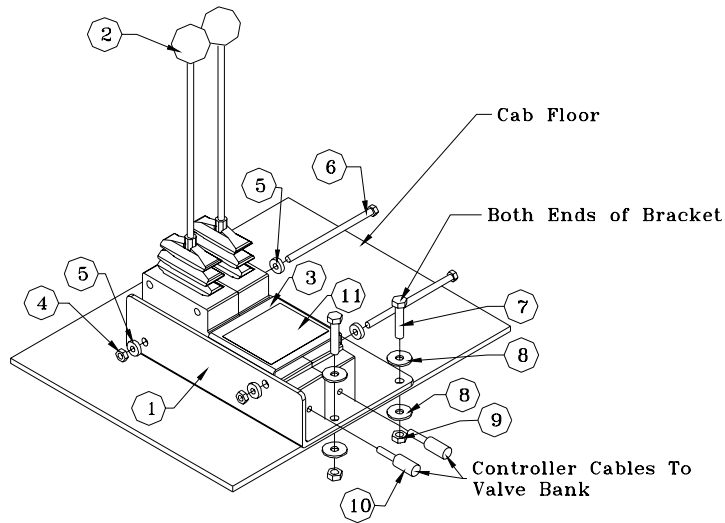

Controllers

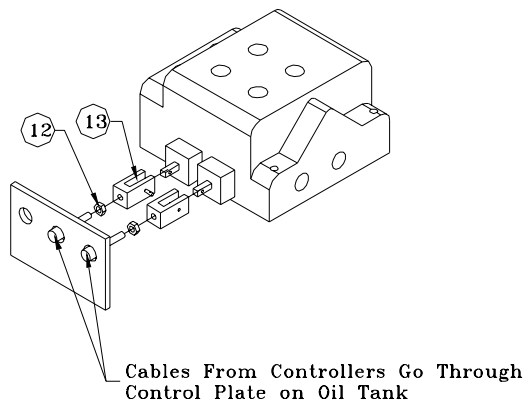

Valve Bank

ITEM	P/N	DESCRIPTION	QTY	ITEM	P/N	DESCRIPTION	QTY
1	2103	Bracket Controller	1	8	0343	Washer, 0.31 Flat	8
2	0608	Control Lever	2	9	0342	Nut, 0.31-18 Nyloc	4
3	0663	Bracket, Decal	1	10	0607	Controller Cable	2
4	0333	Nut, 0.25-20 Nyloc	2	11	0651	Decal, Operation	1
5	0340	Washer, 0.25 Flat	4	12	1056	Nut, 0.25 Fine Thread	2
6	0528	Cap Screw, 0.25-20x4.50	2	13	0662	Cable Ends, 0.25	2
7	0486	Cap Screw, 0.31-18x1.50	4				

Subframe

Minimum recommended rail construction.	
84-12-8	5x2x1/4

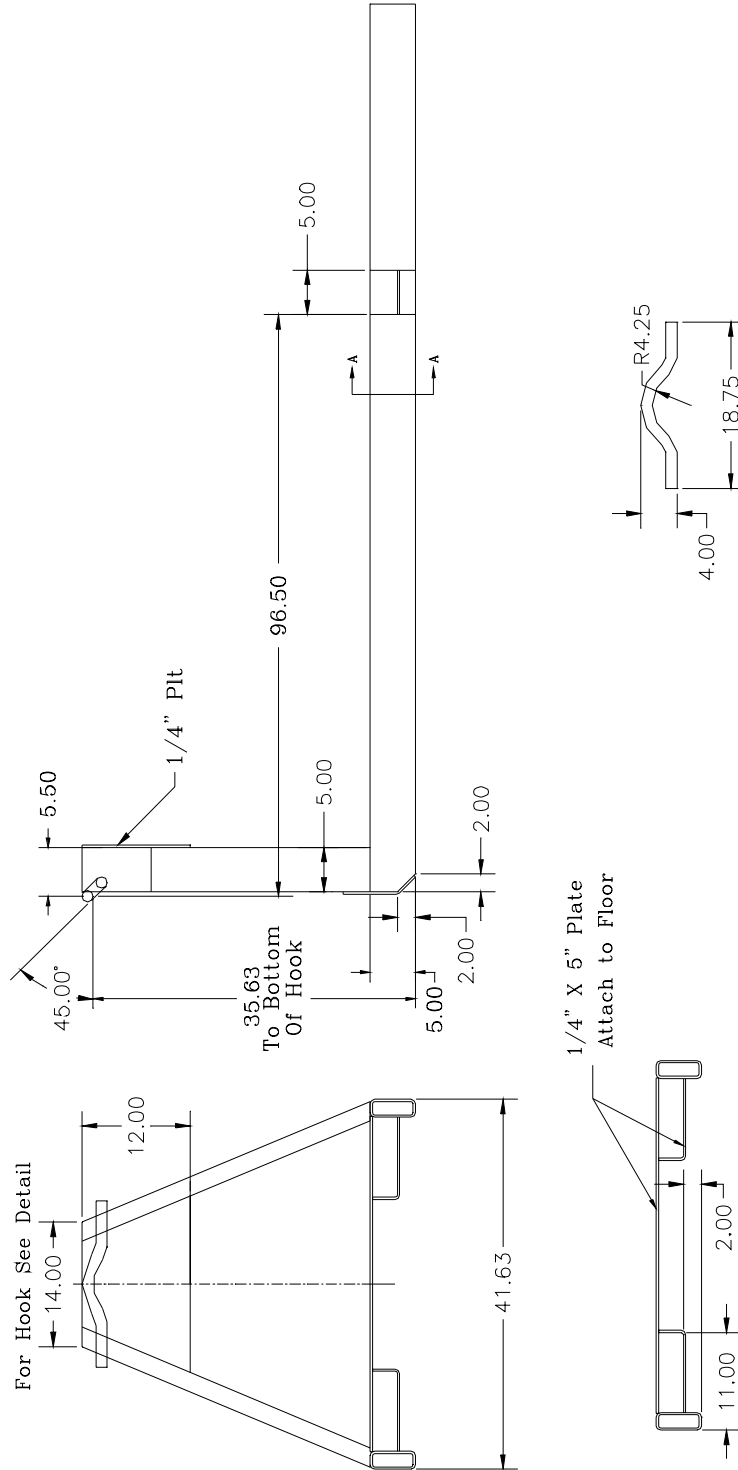

Note: Cap all tube ends.

1.25 Round

Section A-A

Drawing For Dimensional Purposes Only



Limited Warranty Statement

Stellar Industries, Inc. (Stellar) warrants products designed and manufactured by Stellar to be free from defects in material and workmanship under proper use and maintenance. Products must be installed and operated in accordance with Stellar's written instructions and capacities. The warranty period shall cover the following:

Twelve (12) month warranty on parts from the date recorded by Stellar as the in-service date, not to extend beyond twenty-four (24) months from date of manufacture,

Twelve (12) month repair labor from the date recorded by Stellar as the in-service date, not to extend beyond twenty-four (24) month from date of manufacture, and

Thirty-six (36) month warranty on all Stellar Crane and Hooklift structural parts from the date recorded by Stellar as the in-service date, not to extend beyond forty-eight (48) months from date of manufacture.

The in-service date will be derived from the completed warranty registration card. In the event a warranty registration card is not received by Stellar, the factory ship date will be used.

Stellar's obligation under this warranty is limited to, and the sole remedy for any such defect shall be, the repair and/or replacement (at Stellar's option) of the unaltered part and/or component in question. Stellar after-sales service personnel must be notified by telephone, fax, or letter of any warranty-applicable damage within fourteen (14) days of its occurrence. If at all possible, Stellar will ship the replacement part within 24-hours of notification by the most economical, yet expedient, means possible. Expedited freight delivery will be at the expense of the owner.

Warranty claims must be submitted and shall be processed in accordance with Stellar's established warranty claim procedure. Stellar after-sales service personnel must be contacted prior to any warranty claim. A return materials authorization (RMA) account number must be issued to the claiming party prior to the return of any warranty parts. Parts returned without prior authorization will not be recognized for warranty consideration. All damaged parts must be returned to Stellar freight prepaid; freight collect returns will be refused. Freight reimbursement of returned parts will be considered as part of the warranty claim.

Warranty service will be performed by any Stellar new equipment distributor, or by any Stellar-recognized service center authorized to service the type of product involved, or by the Stellar factory in the event of a direct sale. At the time of requesting warranty service, the owner must present evidence of date of delivery of the product. The owner shall be obligated to pay for any overtime labor requested of the servicing company by the owner, any field service call charges, and any towing and/or transportation charges associated with moving the equipment to the designated repair/service provider.

All obligations of Stellar and its authorized dealers and service providers shall be voided if someone other than an authorized Stellar dealer provides other than routine maintenance service without prior written approval from Stellar. In the case repair work is performed on a Stellar-manufactured product, original Stellar parts must be used to keep the warranty in force. The warranty may also be voided if the product is modified or altered in any way not approved, in writing, by Stellar.

The owner/operator is responsible for furnishing proof of the date of original purchase of the Stellar product in question. Warranty registration is the ultimate responsibility of the owner and may be accomplished by the completion and return of the Stellar product registration card provided with the product. If the owner is not sure of registration, he is encouraged to contact Stellar at the address below to confirm registration of the product in question. This warranty covers only defective material and workmanship. It does not cover depreciation or damage caused by normal wear and tear, accident, mishap, untrained operators, or improper or unintended use. The owner has the obligation of performing routine care and maintenance duties as stated in Stellar's written instructions, recommendations, and specifications. Any damage resulting from owner/operator failure to perform such duties shall void the coverage of this warranty. The owner will pay the cost of labor and supplies associated with routine maintenance.

The only remedies the owner has in connection with the breach or performance of any warranty on the Stellar product specified are those set above. In no event will Stellar, the Stellar distributor/dealer, or any company affiliated with Stellar be liable for business interruptions, costs of delay, or for any special, indirect, incidental, or consequential costs or damages. Such costs may include, but are not limited to, loss of time, loss of revenue, loss of use, wages, salaries, commissions, lodging, meals, towing, hydraulic fluid, or any other incidental cost.

All products purchased by Stellar from outside vendors shall be covered by the warranty offered by that respective manufacturer only. Stellar does not participate in, or obligate itself to, any such warranty.

Stellar reserves the right to make changes in design or improvement upon its products without imposing upon itself the same upon its products theretofore manufactured.

This warranty will apply to all Stellar Hooklifts, Stellar Service Trucks, & Truck-mounted Cranes shipped from Stellar's factory after July 1, 2005. The warranty is for the use of the original owner only and is not transferable without prior written permission from Stellar.

THIS WARRANTY IS EXPRESSLY IN LIEU OF ANY OTHER WARRANTIES, EXPRESS OR IMPLIED, INCLUDING ANY WARRANTY OF MERCHANTABILITY OR FITNESS FOR A PARTICULAR PURPOSE. REMEDIES UNDER THIS WARRANTY ARE LIMITED TO THE PROVISION OF MATERIAL AND SERVICES, AS SPECIFIED HEREIN. STELLAR INDUSTRIES, INC. IS NOT RESPONSIBLE FOR INCIDENTAL OR CONSEQUENTIAL DAMAGES.

Revision Date: February 2007

Document Number: 37040